

ICC-ES Evaluation Report

ESR-2233*
Issued October 1, 2007
This report is subject to re-examination in two years.
www.icc-es.org | (800) 423-6587 | (562) 699-0543

A Subsidiary of the International Code Council®

DIVISION: 06—WOOD AND PLASTICS
Section: 06120—Structural Panels
REPORT HOLDER:
AFM CORPORATION
 17645 JUNIPER PATH, SUITE 260
 LAKEVILLE, MINNESOTA 55044
www.r-control.com
EVALUATION SUBJECT:
R-CONTROL® SIPs (STRUCTURAL INSULATED PANELS)
ADDITIONAL LISTEES:
ACH FOAM TECHNOLOGIES, LLC
BIG SKY INSULATIONS, INC.
BRANCH RIVER PLASTICS, INC.
CHAPMAN BUILDING SYSTEMS
ENERGY SYSTEMS INC.
NOARK ENTERPRISES, INC.
TEAM INDUSTRIES, INC.
THERMAL FOAMS, INC.
1.0 EVALUATION SCOPE
Compliance with the following codes:

- 2006 *International Building Code*® (IBC)
- 2006 *International Residential Code*® (IRC)

Properties evaluated:

- Structural
- Thermal barrier
- Fire resistance

2.0 USES

R-Control SIPs are used as structural insulated load-bearing wall, floor and roof panels.

3.0 DESCRIPTION
3.1 General:

R-Control SIPs are factory-laminated sandwich panels consisting of oriented strand board (OSB) facings with

expanded polystyrene (EPS) foam plastic core material. The panels vary in size from 4 feet by 8 feet to 8 feet by 24 feet (1.2 m by 2.4 m to 2.4 m by 7.2 m). Panel thicknesses are from 4¹/₂ inches (114 mm) to 12¹/₄ inches (286 mm).

3.2 Materials:

3.2.1 Expanded Polystyrene: The EPS core thicknesses are 3¹/₂ inches, 5¹/₂ inches, 7¹/₄ inches, 9¹/₄ inches, or 11¹/₄ inches (89 mm, 140 mm, 184 mm, 235 mm, or 286 mm). The EPS core is Foam-Control EPS with Perform Guard, which is recognized in ICC-ES report [ESR-1006](#), and complies with the Type I requirements of ASTM C 578.

3.2.2 Facing: The facing material is 7¹/₁₆-inch-thick (11.1 mm) OSB rated sheathing classified as Exposure I, having a span rating of 24/16, complying with U.S. DOC PS2 and as specified in the approved AFM quality control manual. The facing may be coated on one side with a minimum 0.080-inch (2.03 mm) thickness of Pyrotite Coating ([ESR-1365](#)).

3.2.3 Adhesive: The facing material is factory-laminated to the EPS core material with adhesives as specified in the quality control manual. The adhesives are Type II, Class 2, adhesives recognized in ICC-ES evaluation reports covering sandwich panel adhesives.

3.2.4 Splines: R-Control SIPs are connected with splines as required by Tables 4 through 7. The splines consist of OSB, dimensional lumber, I-beams, or insulated I-beams. OSB splines consist of two nominally 4-inch-wide-by-7¹/₁₆-inch-thick OSB strips of the same material as described in Section 3.2.2. Dimensional lumber splines consist of two nominally 2-by spruce-pine-fir No. 2 or better wood members having a depth to match the core thickness of the panels. I-beam splines are single-web I-joint recognized in [ESR-1077](#) and manufactured in depths of 7¹/₄ inches, 9¹/₄ inches, and 11¹/₄ inches (184, 235 and 286 mm). Insulated I-beam splines are double-web wood I-joints manufactured in depths of 5¹/₂ inches, 7¹/₄ inches, 9¹/₄ inches, and 11¹/₄ inches (133, 184, 235 and 286 mm).

3.2.5 Thermal Barrier: The thermal barrier must be gypsum board with a minimum 1¹/₂-inch (12.5 mm) thickness and must comply with ASTM C 36 or ASTM C 1396, or the facing must be coated with Pyrotite as described in [ESR-1365](#).

3.3 Panels:

3.3.1 Wall Panels: R-Control SIP wall panels consist of the OSB facings bonded to 3¹/₂-inch or 5¹/₂-inch (88.9 or 139.7 mm) EPS cores. The panels are fabricated in widths

*Revised June 2009, Corrected July 2009

of up to 8 feet (2438 mm). Refer to Table 2 for panel heights. The panels are manufactured with full-height panel facings without intermediate joints. The core is recessed 1½ inches (38 mm) from the top panel edge and 1½ inches (38 mm) from the bottom panel edge. The recesses receive nominally 2-inch (51 mm) plates; the plates are installed at the jobsite. Top and bottom plates must be nominally 2-by spruce-pine-fir No. 2 or better, with a depth of the plates to match the EPS core thickness. The core is recessed on the side of the panel to receive OSB splines; the OSB splines are factory-supplied and installed at the jobsite. The OSB spline is nailed to the panel facing at the jobsite with 8d common nails spaced 6 inches on center. When used as shear walls, the panels are recognized for use in Seismic Design Category A, B or C.

3.3.2 Floor Panels: R-Control SIP floor panels are fabricated in widths of up to 8 feet (2438 mm) in accordance with Table 4 and up to 4 feet (1219 mm) in accordance with Tables 5 through 7. Refer to Tables 4 through 7 for EPS core thicknesses and panel lengths. The panels are manufactured with full-length panel facings without intermediate joints. The core is recessed along the longitudinal panel edges to receive a spline; refer to Section 3.2.4 and Tables 4 through 7 for spline configuration. The spline is nailed at the jobsite to the panel facing with 8d common nails spaced 6 inches (152 mm) on center.

3.3.3 Roof Panels: R-Control SIP roof panels are fabricated in widths up to 8 feet (2438 mm) in accordance with Table 4 and up to 4 feet (1219 mm) in accordance with Tables 5 through 7. Refer to Tables 4 through 7 for EPS core thicknesses and panel lengths. The roof panels are manufactured with full-length panel facings without intermediate longitudinal joints. The core is recessed along the longitudinal panel edges to receive a spline; refer to Section 3.2.4 and Tables 4 through 7 for spline configuration. The spline is nailed to the panel facing with 8d common nails spaced 6 inches on center.

3.3.4 R-Control Screws: Screws used for the connection of SIPs as specified in Table 9 are corrosion-resistant steel wood screws having a minimum shank diameter of 0.188 inch (4.7 mm) and a minimum head diameter of 0.620 inch (15.5 mm). The screws must have sufficient length to penetrate the wood member to which the assembly is being attached by a minimum of 1⅝ inches (41.3 mm).

4.0 DESIGN AND INSTALLATION

4.1 Design:

4.1.1 Allowable Loads: R-Control® SIPs are limited to the loads and loading conditions indicated in Tables 2 through 9 of this report. The allowable loads noted in this report are applicable for noted spans and heights, or for shorter spans or heights. Extrapolation is not permitted. The allowable loads shown in these tables are for the R-Control SIPs only and do not include consideration of the elements supporting the panels, which must conform to the requirements of the IBC or IRC, as applicable.

Openings in the wall panels are limited to the allowable loads specified in Table 8. Openings not covered by Table 8 must be framed to meet requirements in the applicable code.

4.1.2 IRC: When the panels are installed in structures regulated by the IRC, engineered design is required in accordance with IRC Section R301.1.3.

4.2 Installation:

4.2.1 General: R-Control SIPs must be installed in accordance with the manufacturer's published installation

instructions and this evaluation report. The manufacturer's published installation instructions and this report must be strictly adhered to, and a copy of the instructions must be available at all times on the jobsite during installation. The installation instructions within this report govern if there are any conflicts between the manufacturer's instructions and this report.

The R-Control SIPs are connected to each other at the panel edges through the use of splines. The splines are installed with Do-All-Ply® sealant and the panels are attached to the splines with 8d box nails at 6 inches (152.4 mm) on center, or an approved equal.

The top and bottom plates of the panel are dimensional wood plates sized to match the core thickness and installed with Do-All-Ply and fastened with 8d box nails at 6 inches (152.4 mm) on center, or an approved equal. Do-All-Ply sealant is applied along the base plate prior to the panel placement.

4.2.2 Thermal Barrier: The panels must be protected from the interior of the building by an approved 15-minute thermal barrier, such as ½-inch (12.7 mm) gypsum wallboard mechanically attached in accordance with the code. OSB panels factory-coated with a minimum 0.080-inch (2.03 mm) thickness of Pyrotite coating ([ESR-1365](#)) may also be used as a 15-minute thermal barrier provided the panels are installed in accordance with [ESR-1365](#) with the coated face oriented toward the interior of the building.

4.2.3 Panel Cladding:

4.2.3.1 Roof Covering: The roof covering shall comply with the applicable code. Underlayment and flashing shall be installed in accordance with the applicable code. Use of roof coverings with hot-asphalt or hot-coal tar pitch is prohibited except as described in Sections 4.3.3 and 4.3.4.

4.2.3.2 Exterior Wall Covering: Panels, at the time of their erection and placement, shall be covered on the exterior by a water-resistive barrier as required by the applicable code. Under Section 2510.6 of the IBC, when exterior plaster is applied over wood-based sheathing, the water-resistive barrier shall include two layers of Grade D paper. The exterior of the wall panels shall be covered with an approved exterior wall covering. Installation methods shall be in accordance with the code and the manufacturer's recommendations, subject to approval by the local code official.

4.3 Fire-resistance-rated Assemblies:

4.3.1 One-hour Limited Load-bearing Wall Assembly: R-Control SIPs with minimum 3½- to maximum 5½-inch-thick (88.9 mm to 139.7 mm) EPS core and ⅞-inch-thick (11.1 mm) OSB facings are installed with top and bottom plates attached to the OSB facings with 12d common nails spaced 12 inches (305 mm) on center. The panels are covered with two layers of ⅝-inch-thick (15.9 mm), Type X gypsum wallboard on each face. Where the panels are exposed to the exterior, the exterior side shall have ⅝-inch-thick (15.9 mm), Type X, water-resistant core gypsum sheathing complying with ASTM C 79, instead of the gypsum wallboard. The gypsum wallboard is installed vertically, with all joints staggered 16 inches (406.4 mm) on center. The first layer of gypsum is secured with 1⅝-inch-long (41.28 mm) and the second with 2-inch-long (50.8 mm), bugle head self-tapping screws, each spaced 12 inches (305 mm) on center along the perimeter and 24 inches (609.6 mm) on center in the field. The joints are taped and the nails are covered with joint compound in accordance with ASTM C 840. The wall is limited to 9 feet (2.70 m) in height and a maximum superimposed allowable bearing load of 1,800 plf (26 269.02 N/m).

4.3.2 One-hour Limited Load-bearing Wall Assembly:

This assembly is applicable to R-Control SIPs with a $5\frac{1}{2}$ -inch-thick (139.7 mm) EPS core and $\frac{7}{16}$ -inch (11.11 mm) OSB skins. The EPS core is recessed $1\frac{1}{2}$ inches (38.1 mm) along the edges of the panels (along the bottom and both sides), and 3 inches (76.2 mm) along the top, to allow for the installation of a nominally 2-by-6 wood (No. 2 hem-fir) bottom plate, double studs and double top plates. Double studs are assembled together with 16d coated sinker nails, spaced 24 inches (609.6 mm) on center and staggered along the stud length. The double studs are installed as a spline in the recesses between adjoining panels and secured to the OSB of the panels with 8d box nails, spaced 6 inches (152.4 mm) on center, and Do-All-Ply sealant. A gap of $\frac{1}{8}$ inch (3.18 mm) is left between adjoining edges of the OSB panel facers at the double stud locations. The single bottom plate is secured to the OSB with 6d common nails spaced 6 inches (152 mm) on center. The double stud is fastened to the bottom plate with two 16d coated sinker nails, and Do-All-Ply. The first top plate is secured to each stud with two 16d coated sinker nails and Do-All-Ply. The second top plate is installed over the first, secured to the OSB with 6d common nails spaced 6 inches (152.4 mm) on center, and secured to the first top plate with 16d coated sinker nails, spaced 16 inches (406.4 mm) on center, and staggered along the top plate length.

Electrical chases, $1\frac{1}{2}$ inches (38.1 mm) in diameter, may be installed horizontally in the EPS core of wall panels, 16 inches (406.4 mm) and 45 inches (1142 mm) above the bottom of the wall.

The panels are covered with one layer of $\frac{5}{8}$ -inch-thick (15.88 mm) Standard Gypsum Co. Type SG-C gypsum fire-rated wallboard on each face, and secured to the OSB with phosphate-coated cupped-head drywall nails, $1\frac{5}{8}$ inches (41.28 mm) long, spaced 8 inches (203.2 mm) on center along the perimeter of the wallboard and 12 inches (304.8 mm) on center vertically and 16 inches (406.4 mm) on center horizontally in the field of the board. The joints of the wallboard are treated with joint compound and paper tape. The nails are covered with joint compound. The wall is limited to 10 feet (3 m) in height and a superimposed allowable bearing load of 2,200 plf (32 107 N/m).

4.3.3 One-hour Restrained or Unrestrained Roof-ceiling Assembly (see Figure 1):

1. Wood beam: Minimum $4\frac{1}{2}$ -inch-wide-by- $9\frac{1}{2}$ -inch-deep (114 mm by 241 mm) wood beam spaced in accordance with the applicable code and the allowable spans for the SIPs roof panels.
2. Roof covering: Consisting of hot-mopped or cold-application materials compatible with the R-Control SIPs that comply with the code as Class A, B or C roof coverings. For hot-mopped applications, a base ply is required.

In lieu of the item described immediately above, a roof covering consisting of a single-ply roofing membrane that is either ballasted, adhered or mechanically attached is permitted under the membrane manufacturer's current ICC-ES evaluation report.

3. R-Control SIPs: Minimum $3\frac{1}{2}$ -inch-thick-core (89 mm) panels, with minimum $\frac{7}{16}$ -inch-thick (11.1 mm) OSB facings.
4. Side plates: Nominally 2-inch-thick wood members, installed in each side joint of the R-Control SIPs, and fastened through the OSB panels with 8d common nails spaced 6 inches (152 mm) on center.
5. End plates: Nominally 2-inch-thick wood blocking installed in each end joint, and fastened through the

OSB panels with 8d common nails spaced 6 inches (152 mm) on center.

6. Gypsum wallboard: Minimum $\frac{5}{8}$ -inch-thick (15.9 mm), 4-foot-wide (1219 mm) panels complying with ASTM C 36 as Type X are installed in two layers on the bottom of the SIPs roof panels with the long dimension perpendicular to the wood beams. The inner layer is attached to the panels using $1\frac{1}{4}$ -inch-long (31.7 mm), Type S, buglehead steel screws spaced 8 inches (203 mm) on center along the joints and in rows spaced 16 inches (406 mm) on center, located $\frac{1}{2}$ inch (12.7 mm) from the edges. The joints of the inner layer of the wallboard must be staggered from the joints of the panels. The outer layer is attached to the panels using 2-inch-long (51 mm), buglehead steel screws spaced 8 inches (203 mm) on center along the edges and located $\frac{3}{4}$ inch (19.1 mm) from the edge, and in rows 12 inches (305 mm) on center in the field. The joints of the outer layer must be staggered from the joints of the inner layer. For beams, two layers of $\frac{5}{8}$ -inch-thick (15.9 mm) gypsum wallboard are fastened to the wood beam using $1\frac{1}{4}$ -inch-long (31.8 mm), Type S, buglehead steel screws spaced 8 inches (203 mm) on center, with the outer layer fastened to the wood beam using 2-inch-long (51 mm), Type S, buglehead steel screws.
7. Joint system: Outer wallboard joints are covered with paper tape and joint compound. Screw heads are covered with joint compound.

4.3.4 One-hour Restrained or Unrestrained Roof-ceiling Assembly (see Figure 2):

1. Steel joist: Type 10K1, minimum size, designed, constructed and installed in accordance with the Steel Joist Institute (SJI) specifications for open web joist and joist girders, as referenced in Section 2206 of the IBC.
2. Roof covering: Consisting of hot-mopped or cold-application materials compatible with the R-Control SIPs that comply with the applicable code as Class A, B or C coverings. For hot-mopped applications, a base ply is required.

In lieu of the item described immediately above, a roof covering consisting of a single-ply roofing membrane that is either ballasted, adhered or mechanically attached is permitted under the membrane manufacturer's current ICC-ES evaluation report.

3. R-Control SIPs: Minimum $3\frac{1}{2}$ -inch-thick-core (89 mm) panels with minimum $\frac{7}{16}$ -inch-thick (11.1 mm) OSB facings.
4. Spline: Nominally 4-inch-wide-by- $\frac{7}{16}$ -inch-thick OSB spline installed between the R-Control SIPs in accordance with spline detail SIP-102 shown in Table 4.
5. End plates: Nominally 2-inch-wide wood blocking installed in each end joint and fastened through the OSB panel with 8d common nails spaced 6 inches (152 mm) on center.
6. Metal lath: Diamond mesh, $\frac{3}{8}$ -inch (9.5 mm) expanded galvanized steel lath weighing 3.4 pounds per square yard (1.3 kg/m²), complying with ASTM C 847. The lath is secured to one side of the joist using No. 20 SWG steel tie wire located at the mid-height of every other web member. Additional lath is installed on the bottom surface of building units and secured by means of 1-inch-wide-by- $1\frac{1}{2}$ -inch-long (25.4 mm by 38 mm) staples spaced 7 inches (178 mm) on center.
7. Spray-applied fire-resistive materials: The material must be CAFCO BLAZE-SHIELD Type DC-F, recognized in ICC-ES evaluation report [ESR-1649](#). Type DC-F is prepared and applied to wetted surfaces of steel joists,

to the bottom surfaces of the R-Control SIPs, and to metal lath, all of which are made free of dirt, oil or loose scale by spraying with water, to achieve a minimum 2¹/₄-inch (57 mm) thickness. The measured individual and average minimum fiber density must be 11 pcf and 12 pcf (176 and 192 kg/m³), respectively. For method of density determination, refer to Section 1704.10 of the IBC. Compliance with installation and inspection requirements described in ICC-ES report [ESR-1649](#) is necessary.

5.0 CONDITIONS OF USE

The R-Control SIPs as described in this report comply with, or are suitable alternatives to what is specified in, those codes listed in Section 1.0 of this report, subject to the following conditions:

- 5.1 The panels are fabricated, identified, and erected in accordance with this report and the manufacturer's published installation instructions. If there is a conflict between this report and the manufacturer's instructions, this report governs.
- 5.2 A thermal barrier is required as noted in Section 4.2.2 of this report.
- 5.3 Design loads to be resisted by the panels must be determined in accordance with the applicable code, and must not exceed the allowable panel loads noted in this report.
- 5.4 Construction documents, including engineering calculations and drawings providing floor plans, window details, door details, and connector details, must be submitted to the code official when application is made for a permit, verifying compliance with this report and the applicable code. The design calculations and details must be prepared by a registered design professional where required by the statutes of the jurisdiction in which the project is to be constructed.
- 5.5 R-Control SIPs must be installed a minimum of 6 inches (152mm) above finish grade.
- 5.6 R-Control SIPs with EPS foam cores with thicknesses of 7¹/₄, 9¹/₄ and 11¹/₄ inches (184, 235 and 286 mm) may be used only as roof or floor panels.

- 5.7 R-Control SIPs may be used as one-hour fire-resistive assemblies when constructed in accordance with Section 4.3.
- 5.8 The panels are limited to use in buildings of Type V construction.
- 5.9 When used as shear walls, the panels are recognized for use in Seismic Design Categories A, B and C.
- 5.10 The panels and their attachments are subject to inspection by the code official prior to covering with an approved water-resistive barrier or approved roof covering.
- 5.11 Justification must be submitted to the code official demonstrating that the R-Control SIPs panels with the roof covering comply as a Class A, B or C roof assembly as required by IBC Sections 1505 and 2603.6 or IRC Section R902, with the classification complying with the minimum classification requirements for the building.
- 5.12 The panels are manufactured by the listees noted in this report, at the locations specified in Table 1, under a quality control program with inspections by PFS Corporation (AA-652).

6.0 EVIDENCE SUBMITTED

- 6.1 Data in accordance with the ICC-ES Acceptance Criteria for Sandwich Panels (AC04), dated June 2007 (editorially revised April 2008).
- 6.2 Reports of fire resistance tests in accordance with ASTM E 119, UBC Standard 7-1, UL 1715 and UBC Standard 26-3.
- 6.3 Reports of diaphragm load tests.

7.0 IDENTIFICATION

Each R-Control SIPs panel is marked with the report holder's name (AFM) and plant identification number (see Table 1 for plant ID numbers); the product name (R-Control[®] SIPs); the name or logo of the inspection agency (PFS Corporation); and the evaluation report number (ESR-2233). Panels having a Pyrotite coating must also be labeled in accordance with [ESR-1365](#).

TABLE 1—MANUFACTURING LOCATIONS

LISTEE	LOCATION	PLANT ID NO.
ACH Foam Technologies, LLC	5250 North Sherman Street Denver, Colorado 80216	U-1
Big Sky Insulations, Inc.	15 Arden Drive Belgrade, Montana 59714	U-30
Branch River Plastics, Inc.	15 Thurber Boulevard Smithfield, Rhode Island 02917	U-6
Chapman Building Systems	5275 Highway 27 East Kerrville, Texas 78028	U-25A
Energy Systems Inc.	5055 South National Drive Knoxville, Tennessee 37914	U-04A
Noark Enterprises, Inc.	10101 Highway 70 East North Little Rock, Arkansas 72117	U-24
Team Industries, Inc.	326 McGhee Road Winchester, Virginia 22603	U-14
Team Industries, Inc.	4580 Airwest Drive SE Grand Rapids, Michigan 49512	U-12
Thermal Foams, Inc.	2101 Kenmore Ave Buffalo, New York 14207	U-26

WALL—UNITY EQUATION

This equation is used to determine design suitability. The equation takes into account the ultimate load for a panel subjected to both axial and transverse (bending) conditions:

$$\frac{\text{design axial load}}{\text{allowable axial load}} + \frac{\text{design transverse load}}{\text{allowable transverse load}} \leq 1$$

(See Table 2) (See Table 4)

TABLE 2—WALL AXIAL LOADING^{1,2,3,4}
(See Detail SIP-101)

R-CONTROL® STRUCTURAL INSULATED PANELS			
	Panel Height	7/16" OSB Thickness	
		EPS Core Thickness	
		3 1/2-inch Core	5 1/2-inch Core
Axial Load ¹ (plf)	8' - 0"	2,750	4,000
	10' - 0"	2,500	3,500
	12' - 0"	2,000	3,000
	14' - 0"	—	2,750
	16' - 0"	—	2,500

For **SI**: 1 inch = 25.4 mm, 1 foot = 304.8 mm, 1 psf = 47.9 Pa, 1 plf = 14.59 N/m.

N/A = not applicable.

¹Maximum allowable axial load is limited to the loads tabulated for axial condition alone.

²For fire-resistive assemblies, see Section 4.3 for axial loading.

³Values based on a maximum height-to-width ratio of 3 1/2:1.

⁴See plate connection detail SIP-101.

TABLE 3—SHEAR LOADING^{1,2}
(See Detail SIP-101)

R-CONTROL® STRUCTURAL INSULATED PANELS			
	Panel Height	7/16-inch OSB Thickness	
		EPS Core Thickness	
		3 1/2-inch Core	5 1/2-inch Core
Racking Shear	N/A	335 plf	335 plf

For **SI**: 1 inch = 25.4 mm, 1 plf = 14.59 N/m.

¹Vertical boundaries of shear walls require double studs.

²The racking shear load is based on a maximum shear wall height to length ratio of 1:1.

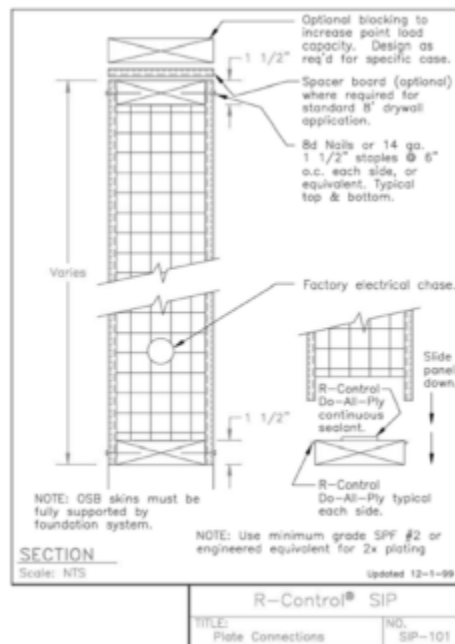

TABLE 4—TRANSVERSE LOADING (psf)^{2,3,4}
 (See Details SIP-102 and SIP-102g)

R-CONTROL® STRUCTURAL INSULATED PANELS																
Roof and Wall or Floor Panel Span		7/16-inch OSB Thickness														
		EPS Core Thickness														
		3 1/2-inch Core			5 1/2-inch Core			7 1/4-inch Core			9 1/2-inch Core			11 1/4-inch Core		
Deflection	L/360	L/240	L/180	L/360	L/240	L/180	L/360	L/240	L/180	L/360	L/240	L/180	L/360	L/240	L/180	
T r a n s v e r s e L o a d (psf)	4' - 0"	65	80 ¹	80 ¹	89	122 ¹	122 ¹	92	136 ¹	136 ¹	107	136 ¹	136 ¹	104	136 ¹	136 ¹
	6' - 0"	40 ⁵	53 ^{1.5}	53 ^{1.5}	58	81 ¹	81 ¹	64	96 ¹	96 ¹	75	96 ¹	96 ¹	73	96 ¹	96 ¹
	8' - 0"	28 ⁵	40 ^{1.5}	40 ^{1.5}	42	61 ¹	61 ¹	51 ¹	76 ¹	76 ¹	61	76 ¹	76 ¹	60	76 ¹	76 ¹
	10' - 0"	20 ⁵	30 ⁵	32 ^{1.5}	32 ⁵	48	49 ¹	44	64 ¹	64 ¹	54 ¹	64 ¹	64 ¹	55	64 ¹	64 ¹
	12' - 0"	15 ⁵	22 ⁵	27 ^{1.5}	26 ⁵	38 ⁵	41 ^{1.5}	40	56 ¹	56 ¹	51	56 ¹	56 ¹	55	56 ¹	56 ¹

For SI: 1 inch = 25.4 mm, 1 foot = 304.8 mm, 1 psf = 47.88 Pa.

NP = not permitted

¹Limited to ultimate failure load divided by a safety factor of 3.0.

²Floor panels limited to Group R Occupancies.

³Wall panels have 7 1/4-inch maximum core thickness.

⁴See surface spline detail SIP-102 and SIP-102g.

⁵Panels may not be used when subject to roof maintenance workers.

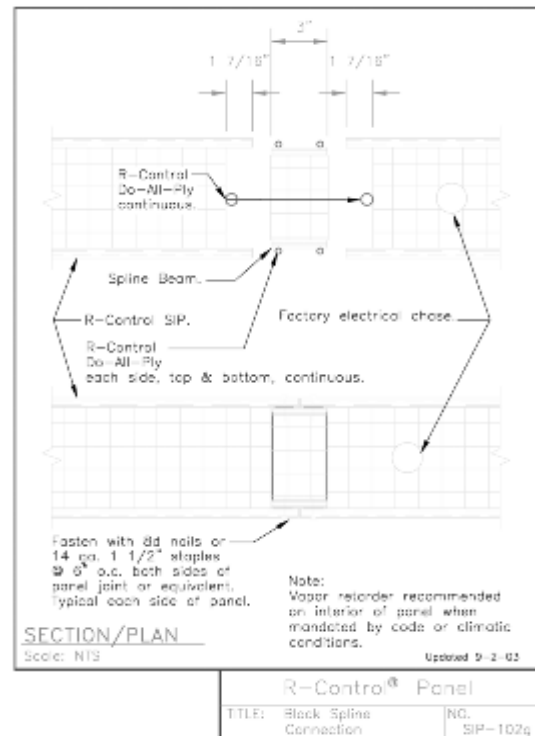
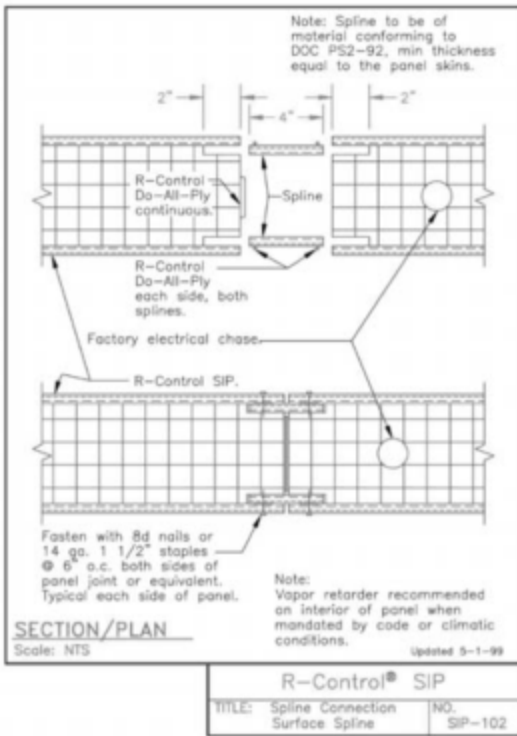

TABLE 5—TRANSVERSE LOAD^{2,3,4}
 (See Details SIP-102d and SIP-108)

R-CONTROL® STRUCTURAL INSULATED PANELS													
Roof, Wall or Floor Panel Span		⁷ / ₁₆ -inch OSB Thickness											
		EPS Core Thickness											
		5 ¹ / ₂ -inch Core			7 ¹ / ₄ -inch Core			9 ¹ / ₄ -inch Core			11 ¹ / ₄ -inch Core		
Deflection		L/360	L/240	L/180	L/360	L/240	L/180	L/360	L/240	L/180	L/360	L/240	L/180
T r a n s v e r s e	10' - 0"	53	79	105 ¹	89	109 ¹	109 ¹	150	174 ¹	174 ¹	177 ¹	177 ¹	177 ¹
	12' - 0"	40	59	79	65	91 ¹	91 ¹	111	145 ¹	145 ¹	148 ¹	148 ¹	148 ¹
	14' - 0"	30 ⁵	45	60	48	72	78 ¹	84	124 ¹	124 ¹	115	127 ¹	127 ¹
	16' - 0"	24 ⁵	35	47	37	55	68 ¹	65	98	109	89	111	111 ¹
	18' - 0"	19 ⁵	28 ⁵	37	28 ⁵	42	57	51	77	97 ¹	70	99 ¹	99 ¹
	20' - 0"	15 ⁵	22 ⁵	30 ⁵	22 ⁵	33	44	41	61	82	56	84	89 ¹
L o a d (psf)	22' - 0"	NP	NP	NP	NP	NP	NP	33	49	66	45	68	81 ¹
	24' - 0"	NP	NP	NP	NP	NP	NP	275	40	54	37	55	74

For **SI**: 1 inch = 25.4 mm, 1 foot = 304.8 mm, 1 psf = 47.9 Pa.

NP = not permitted

¹Limited to ultimate failure load divided by a safety factor of 3.0.

²Roof, wall and floor panels are framed with continuous doubled nominal 2-inch lumber in the spanning direction, spaced 4 feet on center, and single nominal 2-inch lumber at panel ends. Lumber is minimum spruce-fir No. 2 grade. Panels below and to the right of heavy line require Douglas fir-larch, No. 2 grade lumber.

³Top facing thickness for floor panels is ³/₄ inch, minimum. As an option, minimum ⁷/₁₆-inch top facing may be overlaid with a minimum ⁷/₁₆-inch finish flooring perpendicular to the panels.

⁴See details SIP-102d and SIP-108.

⁵Panels may not be used when subject to roof maintenance workers.

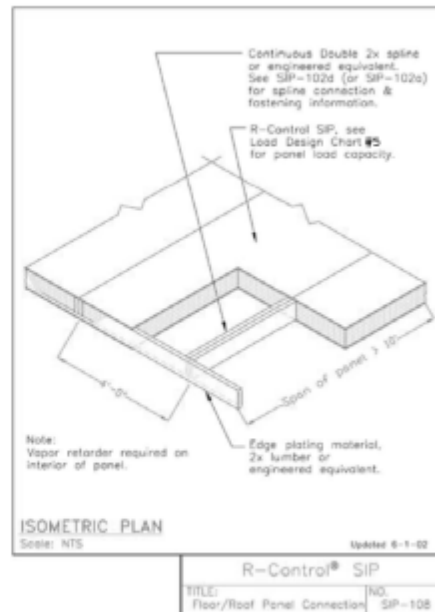
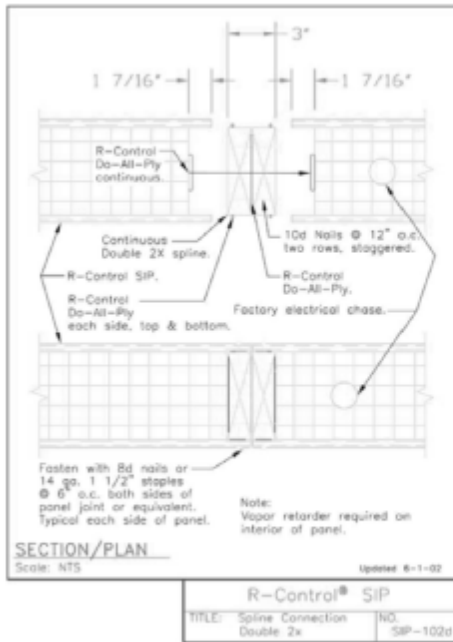

TABLE 6—TRANSVERSE LOADING^{2,3,4,5,6}
 (See Details SIP-102b and SIP-108a)

R-CONTROL® STRUCTURAL INSULATED PANELS										
Roof or Floor Panel Span		7/16-inch OSB Thickness								
		EPS Core Thickness								
		7 1/4-inch Core			9 1/4-inch Core			11 1/4-inch Core		
Deflection		L/360	L/240	L/180	L/360	L/240	L/180	L/360	L/240	L/180
T r a n s v e r s e L o a d (psf)	10' - 0"	81 ¹	81 ¹	81 ¹	118 ¹	118 ¹	118 ¹	131 ¹	131 ¹	131 ¹
	12' - 0"	63	68 ¹	68 ¹	98 ¹	98 ¹	98 ¹	109	109 ¹	109 ¹
	14' - 0"	49	58 ¹	58 ¹	73	84 ¹	84 ¹	87	93 ¹	93 ¹
	16' - 0"	38	51 ¹	51 ¹	55	74 ¹	74 ¹	69	82 ¹	82 ¹
	18' - 0"	30 ⁶	45 ¹	45 ¹	42	63	65 ¹	55	72	72
	20' - 0"	24 ⁶	37	40 ¹	33	49	59 ¹	45	65	65
	22' - 0"	NP	NP	NP	26 ⁶	39	49 ¹	37	55	57 ¹
	24' - 0"	NP	NP	NP	21 ⁶	31 ⁶	41	30 ⁶	46	48 ¹

For **SI**: 1 inch = 25.4 mm, 1 foot = 304.8 mm, 1 psf = 47.9 Pa.

NP = not permitted.

¹Limited to ultimate failure load divided by a safety factor of 3.0.

²Panels require continuous wood I-beams installed in the spanning direction spaced 4 feet on center.

³Top facing thickness for floor panels in minimum 3/4 inch. As an option, the minimum 6/16-inch-thick top facing may be overlaid with minimum 7/16-inch-thick finish flooring perpendicular to the panels.

⁴Wood I-joist is SWI-T-34 recognized in ICC-ES report [ESR-1077](#).

⁵See details SIP-102b and SIP-108a.

⁶Panels may not be used when subject to roof maintenance workers.

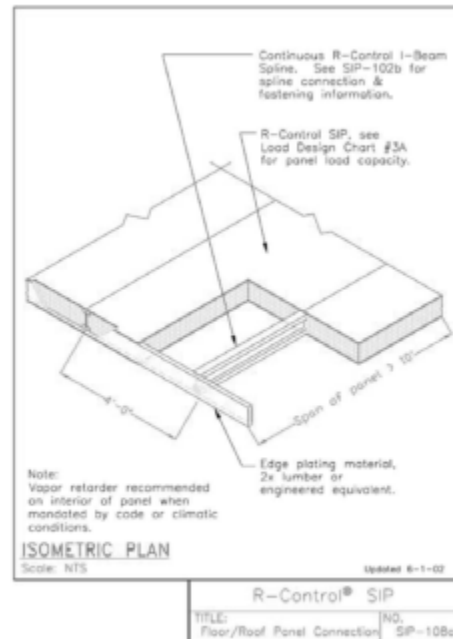
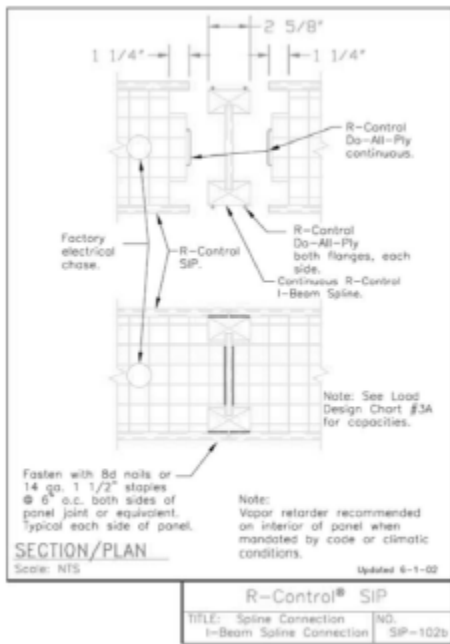

TABLE 7—TRANSVERSE LOADING^{2,3,4}
 (See Details SIP-102c and SIP-108b)

R-CONTROL® STRUCTURAL INSULATED PANELS													
Roof or Floor Panel Span		⁷ / ₁₆ -inch OSB Thickness											
		EPS Core Thickness											
		5 ¹ / ₂ -inch Core			7 ¹ / ₄ -inch Core			9 ¹ / ₄ -inch Core			11 ¹ / ₄ -inch Core		
Deflection		L/360	L/240	L/180	L/360	L/240	L/180	L/360	L/240	L/180	L/360	L/240	L/180
T r a n s v e r s e	10' - 0"	76	114	132 ¹	101	151	158 ¹	117	138 ¹	138 ¹	149 ¹	149 ¹	149 ¹
	12' - 0"	57	79	96 ¹	72	109	132 ¹	88	115 ¹	115 ¹	124 ¹	124 ¹	124 ¹
	14' - 0"	38	57	70 ¹	54	80	107 ¹	68	98 ¹	98 ¹	106 ¹	106 ¹	106 ¹
	16' - 0"	28 ⁵	42	54 ¹	40	61	81	53	80	86 ¹	76	93 ¹	93 ¹
	18' - 0"	21 ⁵	32 ⁵	42	31 ⁵	47	62	42	64	64 ¹	64	83	83
L o a d	20' - 0"	16 ⁵	24 ⁵	32 ⁵	24 ⁵	36	49	34	51	52 ¹	50	74 ¹	74 ¹
	22' - 0"	NP	NP	NP	NP	NP	NP	28 ⁵	42	43 ¹	40	60	62
	24' - 0"	NP	NP	NP	NP	NP	NP	23 ⁵	34	36 ¹	33	49	52 ¹
(psf)													

For SI: 1 inch = 25.4 mm, 1 foot = 304.8 mm, 1 psf = 47.9 Pa.

NP = not permitted

¹Limited to ultimate failure load divided by a safety factor of 3.0.

²Panels require continuous insulated spline beams installed in the spanning direction spaced 4 feet on center.

³Top facing thickness for floor panels is ³/₄ inch, minimum. As an option, the minimum ⁷/₁₆-inch-thick top facing may be overlaid with minimum ⁷/₁₆-inch-thick finish flooring perpendicular to the panels.

⁴See details SIP-102c and SIP-108b.

⁵Panels may not be used when subject to roof maintenance workers.

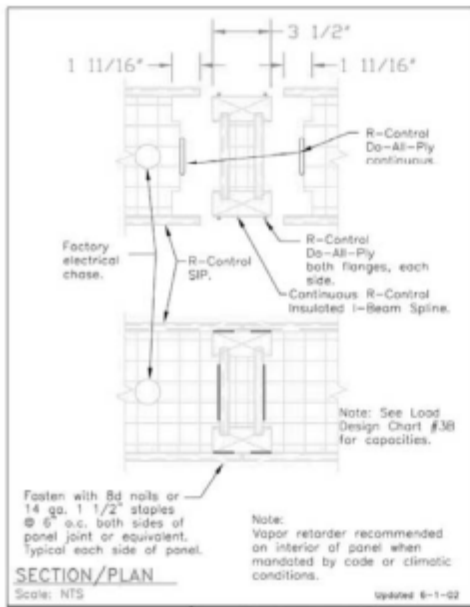

R-Control® SIP
 TITLE: Spine Connection Insulated I-Beam Spine NO. SIP-102c

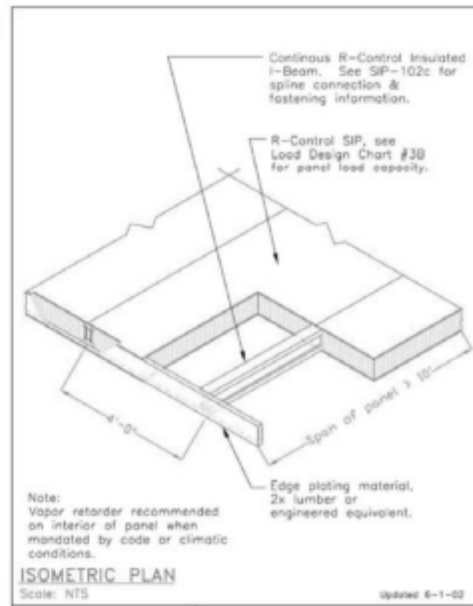

R-Control® SIP
 TITLE: Floor/Roof Panel Connection NO. SIP-108b

TABLE 8—WALL-HEADER LOADING
(See Details SIP-112 and SIP-114)

R-CONTROL® STRUCTURAL INSULATED PANELS ^{2,3,4,5}										
Header Span		Header Depth								
		12 inches			18 inches			24 inches		
Deflection		L/480	L/360	L/240	L/480	L/360	L/240	L/480	L/360	L/240
L o a d (plf)	4' - 0"	524	703	708 ¹	762	773 ¹	773 ¹	837 ¹	837 ¹	837 ¹
	6' - 0"	319	374 ¹	374 ¹	466 ¹	466 ¹	466 ¹	557 ¹	557 ¹	557 ¹
	8' - 0"	218	248 ¹	248 ¹	351 ¹	351 ¹	351 ¹	455 ¹	455 ¹	455 ¹

For **SI**: 1 inch = 25.4 mm, 1 plf = 14.59 N/m.

¹Limited to ultimate failure load divided by a safety factor of 3.0.

²See details SIP-112 and SIP-114.

³Supports and connections shall be designed for each installation.

⁴Top and bottom plates shall be Douglas fir No. 2.

⁵See details SIP-112 and SIP-114.

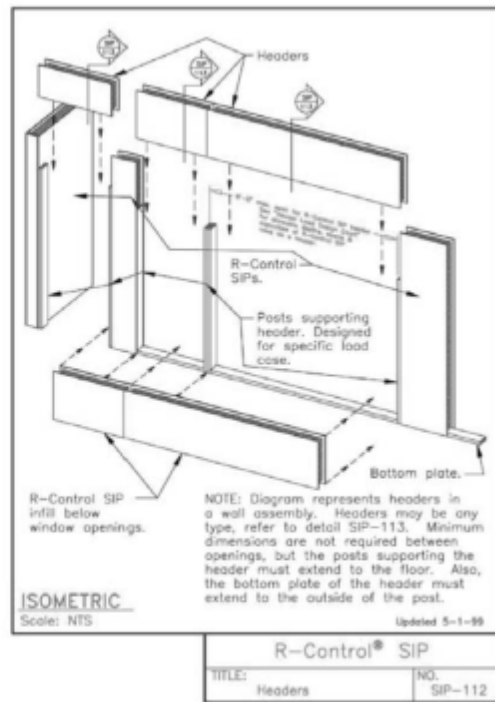
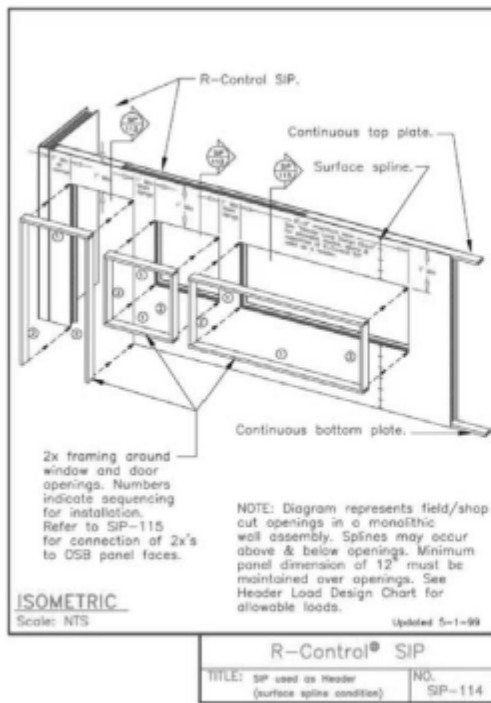
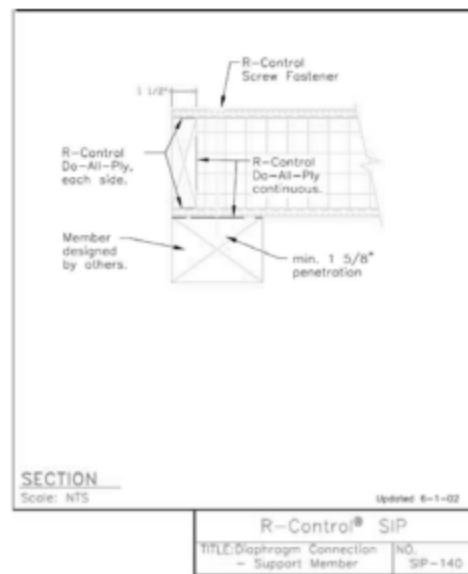
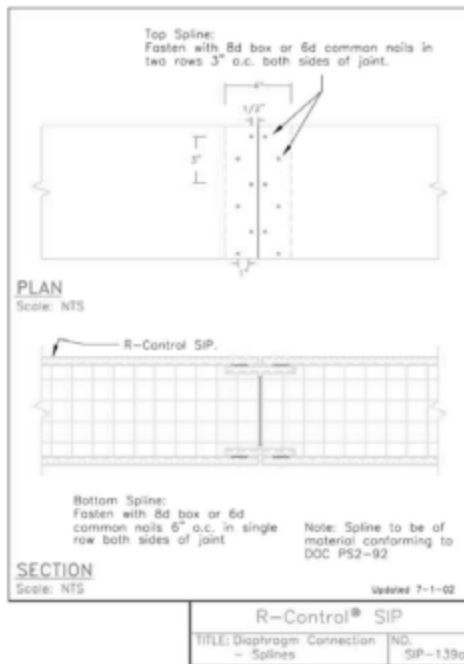

TABLE 9—ROOF/FLOOR-DIAPHRAGM LOADING²
 (See connection details SIP-139a, SIP-140 and SIP-141)

R-CONTROL® STRUCTURAL INSULATED PANELS			
7/16-inch OSB Thickness	Spacing of R-Control Screw Fasteners at supported edges (minimum 1 5/8 inch penetration)		
	3 inches	4 inches	6 inches
	Spacing of spline fasteners (8d box or 6d common) at unsupported edges—top side of panel only—two staggered rows of fasteners on each side of joint.		
	3 inches	3 inches	3 inches
	850 plf ¹	750 plf ¹	500 plf ¹

¹Spline is 7/16-inch OSB x 4.

²See details SIP-139a, SIP-140, and SIP-141.



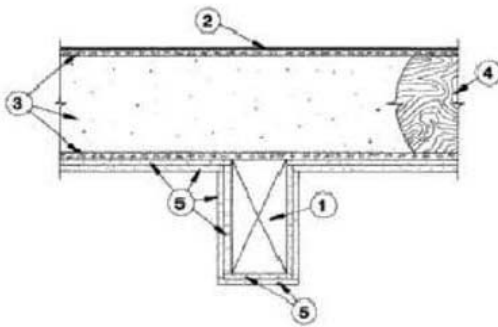
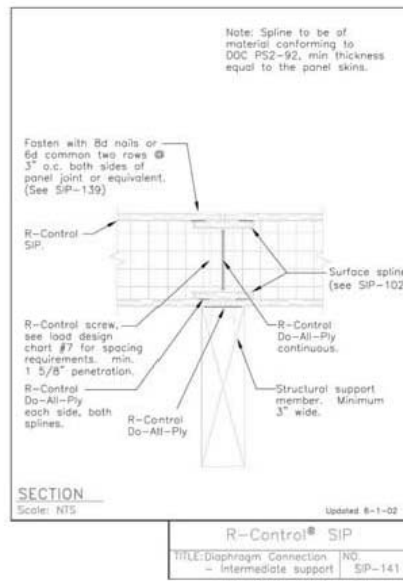

FIGURE 1—UNRESTRAINED ASSEMBLY RATING—1 HOUR

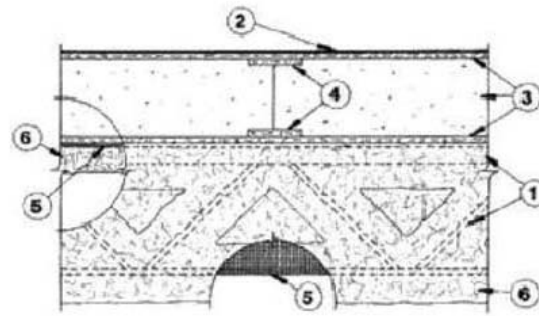

FIGURE 2—UNRESTRAINED ASSEMBLY RATING—1 HOUR

Refer to Sections 4.3.3 and 4.3.4 for installation instructions